

EFGC Flail Mower Main Assembly

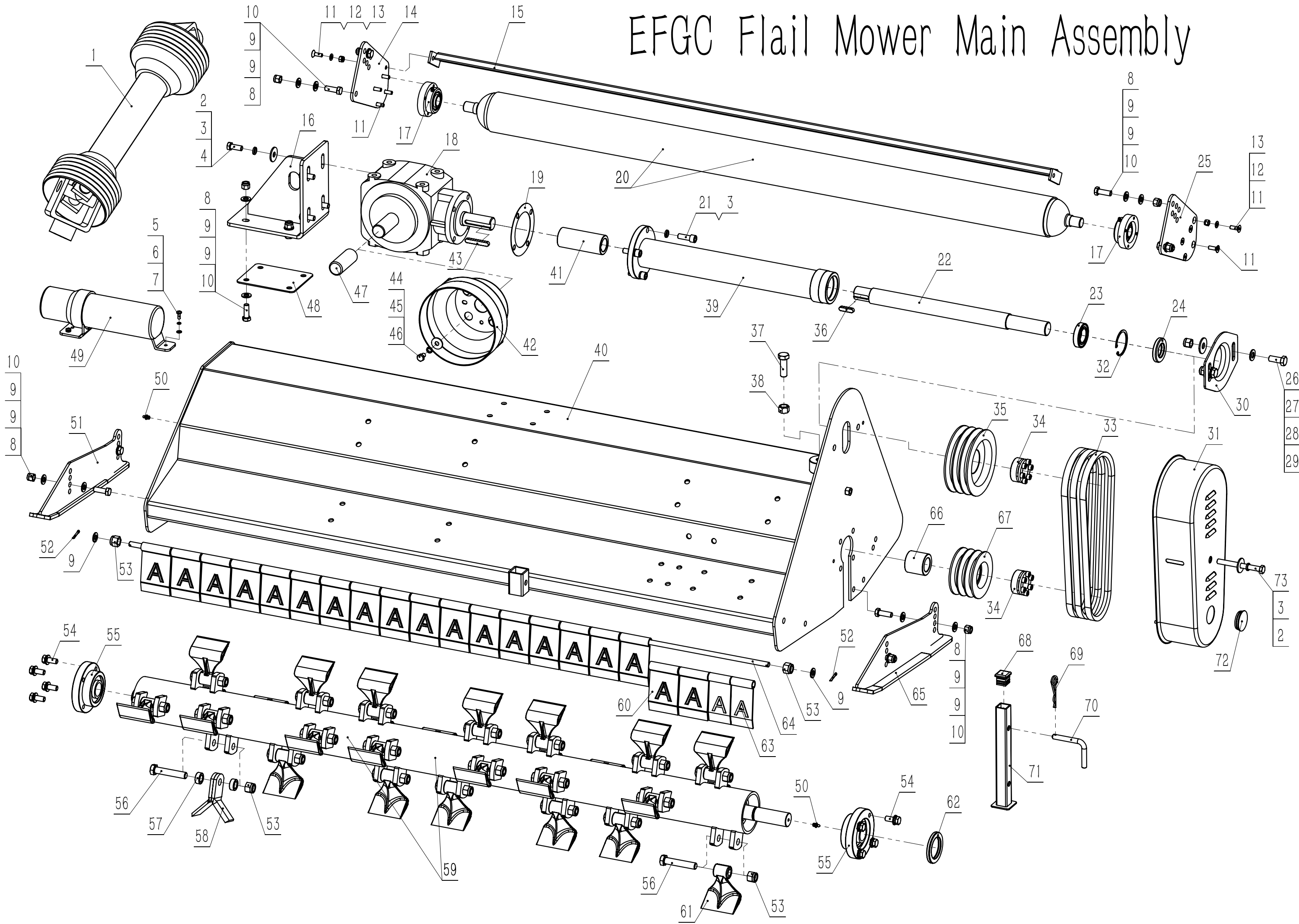

EFGC Flail Mower Lifting Assembly

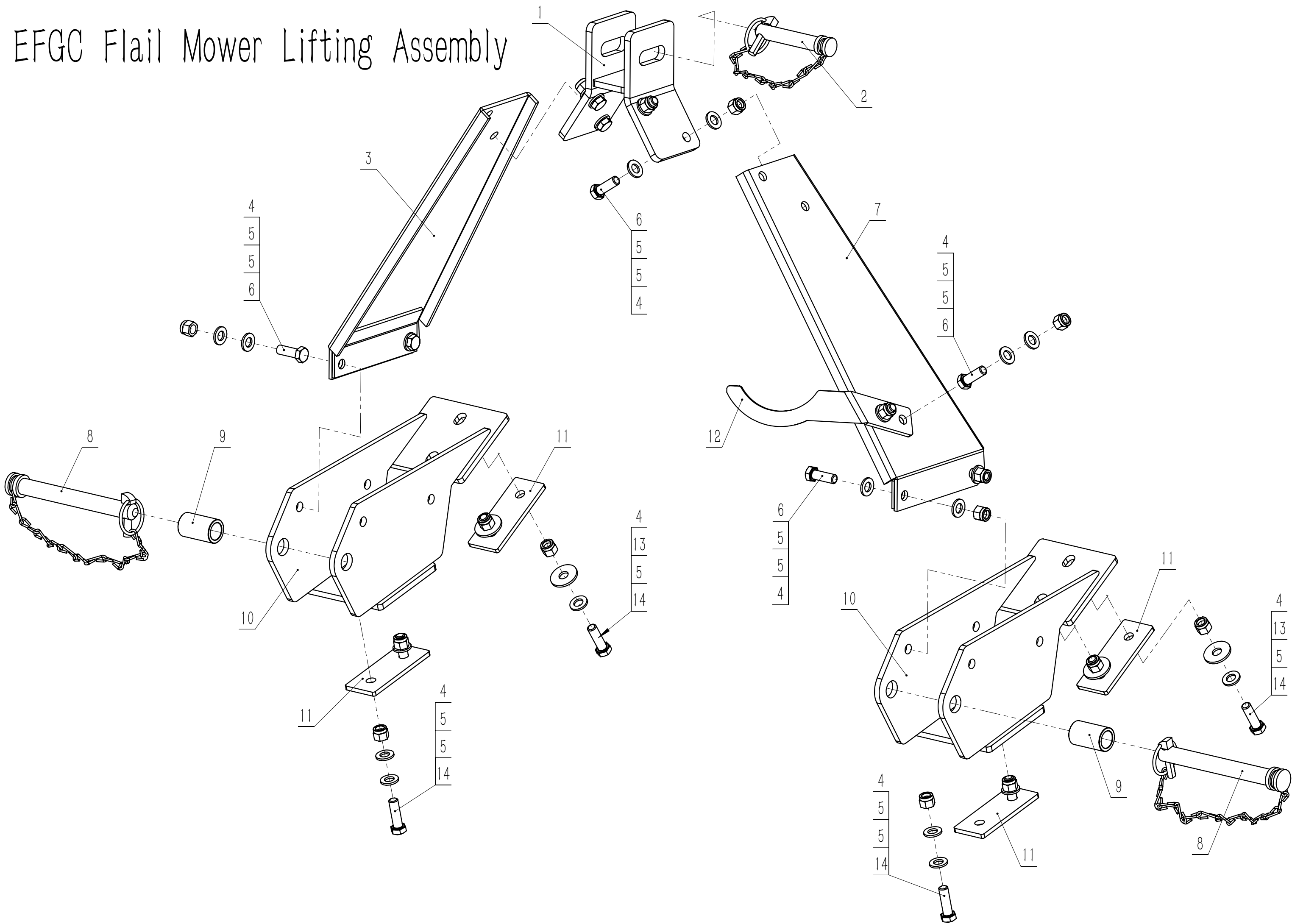

EFGC Flail Mower Main Assembly					
Ser. No.	Part No.	Name & Specification		Quantity	Remarks
1	T4S-Y6W-05-05*800	PTO shaft 04B800	PTO 04B800	1	
2	GB/T 96.1-012	Big washer 12	大平垫 12	5	
3	GB/T 93-012	spring washer 12	弹垫 12	9	
4	GB/T 5783-M12*30	Bolt M12*30	螺栓 M12×30	4	
5	GB/T 97.1-06	washer 6	平垫 6	3	
6	GB/T 93-06	spring washer 6	弹垫 6	3	
7	GB/T 818-M6*16	Cross recessed pan head screwM6*16	十字槽盘头螺钉M6×16	3	
8	GB/T 889.1-M12	Lock nut M12	防松螺母M12	12	
9	GB/T 97.1-012	washer 12	平垫 12	26	
10	GB/T 5783-M12*35	Bolt M12*35	螺栓 M12×35	12	
11	GB/T 70.3-M8*25	Hexagon socket countersunk head screws M8*25	内六角沉头螺钉 M8×25	10	
12	GB/T 97.1-08	washer 8	平垫 8	2	
13	GB/T 889.1-M8	Lock nut M8	防松螺母M8	2	
14	EFGC175.112	Roller connect plate right	滚筒右连接板	1	
15	EFGC105.016	Scraper welded parts for 105	刮泥板焊合件	1	
	EFGC115.016	Scraper welded parts for 115	刮泥板焊合件	1	
	EFGC125.016	Scraper welded parts for 125	刮泥板焊合件	1	
	EFGC135.016	Scraper welded parts for 135	刮泥板焊合件	1	
	EFGC145.016	Scraper welded parts for 145	刮泥板焊合件	1	
	EFGC155.016	Scraper welded parts for 155	刮泥板焊合件	1	

EFGC Flail Mower Main Assembly					
Ser. No.	Part No.	Name & Specification		Quantity	Remarks
	EFGC165.016	Scraper welded parts for 165	刮泥板焊合件	1	
	EFGC175.016	Scraper welded parts for 175	刮泥板焊合件	1	
	EFGC185.016	Scraper welded parts for 185	刮泥板焊合件	1	
	EFGC195.016	Scraper welded parts for 195	刮泥板焊合件	1	
16	EFGC175.025	gearbox bracket parts	齿轮箱安装板焊合件	1	
17	EFGC175.127	UC205	带座外球面轴承UC205	2	
18	XH50.300Z.02W	gearbox	齿轮箱	1	
19	EFGC175.118	Paper pad	纸垫	1	
20	EFGC105.012	back roller for 105	滚筒焊合件	1	
	EFGC115.012	back roller for 115	滚筒焊合件	1	
	EFGC125.012	back roller for 125	滚筒焊合件	1	
	EFGC135.012	back roller for 135	滚筒焊合件	1	
	EFGC145.012	back roller for 145	滚筒焊合件	1	
	EFGC155.012	back roller for 155	滚筒焊合件	1	
	EFGC165.012	back roller for 165	滚筒焊合件	1	
	EFGC175.012	back roller for 175	滚筒焊合件	1	
	EFGC185.012	back roller for 185	滚筒焊合件	1	
	EFGC195.012	back roller for 195	滚筒焊合件	1	
21	GB/T 70.1-M12*35	Hex cylinder head screw M12×35	内六角圆柱头螺钉 M12×35	4	
	EFGC125.104	Drive shaft	传动轴	1	105-125

EFGC Flail Mower Main Assembly

Ser. No.	Part No.	Name & Specification		Quantity	Remarks
22	EFGC155.104	Drive shaft	传动轴	1	135-155
	EFGC175.104	Drive shaft	传动轴	1	165-195
23	GB/T 276-94	Bearing 6007-2RZ	深沟球轴承6007-2RZ	1	
24	GB/T 13871.1	Oil seal 35*62*10	TC型油封35x62x10	1	
25	EFGC175.111	Roller connect plate left	滚筒左连接板	1	
26	GB/T 5783-M14*35	Bolt M14*35	螺栓 M14×35	2	
	GB/T 5783-M14*35	Bolt M14*40	螺栓 M14×40	2	配EFGC175.101
27	GB/T 97.1-014	washer 14	平垫 14	2	
28	GB/T 96.1-014	Big washer 14	大平垫 14	2	
29	GB/T 889.1-M14	Lock nut M14	防松螺母 M14	2	
30	EFGC175.101	connect plate	连接板	1	选配
	EFGC175.101-1	connect plate	连接板	1	
31	EFGC175.014	Belt cover	皮带轮罩焊合件	1	
32	GB/T 893.1	Snap 62	孔用弹性挡圈 62	1	
33	GB/T 11544	Belt XPB 17*1016	皮带 XPB 17*1016	3	
	GB/T 11544	Belt XPB 17*1016	皮带 XPB 17*1016	4	选配
	GB/T 11544	Belt XPC 22*1016	皮带 XPB 22*1016	3	
34	EFGC175.131	Tension 35*60	胀套 35x60	2	
35	EFGC175.106	Big pulley	大皮带轮	1	
	EFGC175.106B	Big pulley	大皮带轮	1	

续前

EFGC Flail Mower Main Assembly					
Ser. No.	Part No.	Name & Specification		Quantity	Remarks
	EFGC175.106C	Big pulley	大皮带轮	1	225件
36	GB/T 1096-2003	flat key 10*40	平键 A10×40	1	
37	GB/T 5786-M16*1.5*50	Bolt M16*1.5*50	螺栓M16×1.5×50	1	
38	GB/T 6185-M16*1.5	Plain thin nut M16*1.5	普通螺母 M16X1.5	1	
39	EFGC125.015	Drive shaft pipe	传动轴管焊合件	1	105-125
	EFGC155.015	Drive shaft pipe	传动轴管焊合件	1	135-155
	EFGC175.015	Drive shaft pipe	传动轴管焊合件	1	165-195
40	EFGC105.011	Main body for 105	机罩焊合件	1	
	EFGC115.011	Main body for 115	机罩焊合件	1	
	EFGC125.011	Main body for 125	机罩焊合件	1	
	EFGC135.011	Main body for 135	机罩焊合件	1	
	EFGC145.011	Main body for 145	机罩焊合件	1	
	EFGC155.011	Main body for 155	机罩焊合件	1	
	EFGC165.011	Main body for 165	机罩焊合件	1	
	EFGC175.011	Main body for 175	机罩焊合件	1	
	EFGC185.011	Main body for 185	机罩焊合件	1	
	EFGC195.011	Main body for 195	机罩焊合件	1	
41	EFGC175.105	sleeve pipe	轴套	1	
42	EFGC175.123	PTO protection	PTO保护罩	1	
43	GB/T 1096	flat key 10*65	平键A 10*65	1	

EFGC Flail Mower Main Assembly					
Ser. No.	Part No.	Name & Specification		Quantity	Remarks
44	GB/T 96.1-010	Big washer 10	大平垫 10	4	
45	GB/T 93-010	spring washer 10	弹垫 10	4	
46	GB/T 5786-M10*16	Bolt M10*16	螺栓M10×16	4	
47	EFGC175.133	Spline housing	花键轴防尘套	1	
48	EFGC175.119	gearbox plate	齿轮箱下垫板	1	
49	EFGC175.132	Instructions box	说明书筒	1	选配
50	JB/T 7940.1	Nipple M8*1	油杯 M8×1	2	
51	EFGC175.018	Left slip plate	左垫板焊合件	1	
52	GB/T 91-2000	Cotter pin A 4*25	开口销 A型 4*25	2	
53	GB/T 889.1-M16	Lock nut M16	防松螺母 M16	30	
54	GB. T 9074.17-M12X30	Composite bolt M12*30	组合螺栓M12*30	8	
55	EFGC175.128	UC207	带座外球面轴承UC207	2	
56	GB/T 5782-M16*85	Bolt M16*85	螺栓 M16×85	N	10.9Level、Black
57	EFGC175.102	Blade sleeve	刀片隔套	N	选配
58	EFGC175.121	Y Blade	Y刀片	2	
59	EFGC105.013	Main roller for 105	刀轴焊合件	1	
	EFGC115.013	Main roller for 115	刀轴焊合件	1	
	EFGC125.013	Main roller for 125	刀轴焊合件	1	
	EFGC135.013	Main roller for 135	刀轴焊合件	1	
	EFGC145.013	Main roller for 145	刀轴焊合件	1	

EFGC Flail Mower Main Assembly

Ser. No.	Part No.	Name & Specification		Quantity	Remarks
59	EFGC155.013	Main roller for 155	刀轴焊合件	1	
	EFGC165.013	Main roller for 165	刀轴焊合件	1	
	EFGC175.013	Main roller for 175	刀轴焊合件	1	
	EFGC185.013	Main roller for 185	刀轴焊合件	1	
	EFGC195.013	Main roller for 195	刀轴焊合件	1	
60	EFGC175.108	Cover big	挡板（通用）	N	
61	EFGC175.125	Hammer	锄头刀片	N	
62	GB/T 13871.1	Oil seal 55*80*8	TC型骨架油封 55*80*8	1	
63	EFGC175.109	Cover Small	挡板（配用）	N	
64	EFGC105.110	Damper shaft for 105	挡板轴	1	
	EFGC115.110	Damper shaft for 115	挡板轴	1	
	EFGC125.110	Damper shaft for 125	挡板轴	1	
	EFGC135.110	Damper shaft for 135	挡板轴	1	
	EFGC145.110	Damper shaft for 145	挡板轴	1	
	EFGC155.110	Damper shaft for 155	挡板轴	1	
	EFGC165.110	Damper shaft for 165	挡板轴	1	
	EFGC175.110	Damper shaft for 175	挡板轴	1	
	EFGC185.110	Damper shaft for 185	挡板轴	1	
	EFGC195.110	Damper shaft for 195	挡板轴	1	
65	EFGC175.019	Right slip plate	右垫板焊合件	1	

EFGC Flail Mower Main Assembly					
Ser. No.	Part No.	Name & Specification		Quantity	Remarks
66	EFGC175.103	sleeve	衬套	1	
67	EFGC175.107	Small pulley	小皮带轮	1	选配
	EFGC175.107B	Small pulley	小皮带轮	1	
	EFGC175.107C	Small pulley	小皮带轮	1	
68	EFGC175.122	Plug	方管塞	1	
69	EFGC175.130	R ring 3.5	R销 3.5	1	
70	EFGC175.115	Pin for support foot	撑脚销	1	
71	EFGC175.023	Support foot	撑脚焊合件	1	
72	FM120.111	Rubber	橡胶罩	1	
73	GB/T 5782-M12*120	Bolt M12*120	螺栓 M12×120	1	